

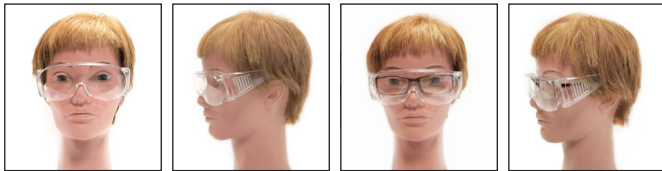

DESCRIPTION

- Light protective goggles, single lens, with molded and integrated side protection, which can be used individually or over prescription glasses
- CE marking - EN166:2001
- Ideal for the Engineering, Construction, Industry, Carpentry and Laboratories sectors
- Clean with warm water, soap and a soft cloth or non-abrasive disinfectant solution
- Store in a clean, dry and dust-free place, preferably in a suitable purpose box
- Designed and produced in Portugal



SINGLE COLOR
011.00167

DIMENSIONS

TECHNICAL FEATURES

Material	Polycarbonate
Length	156mm
Width	155mm
Distance Between Frames	156mm
Weight	40g
CE Conformity	EN166:2001
Optical class	1

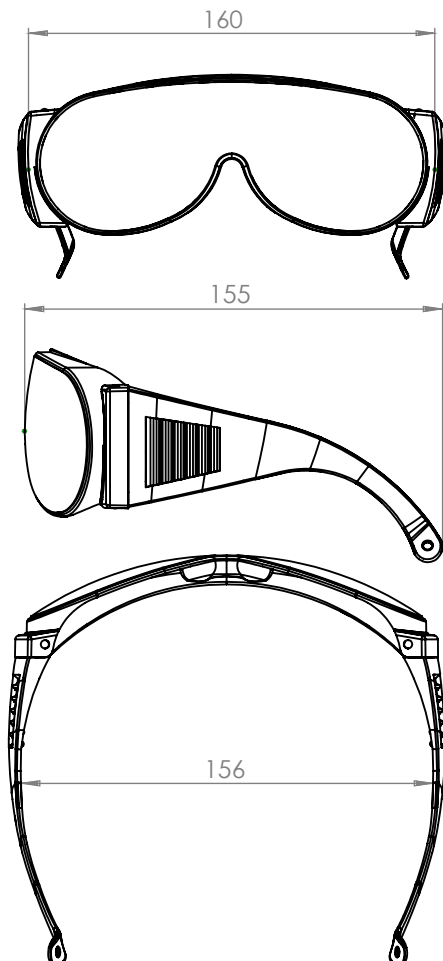

LOGISTIC DATA

Box	400x400x170mm
Quantity	50un
Packaging	Individual Plastic Bag